

Robo4girls User-Documentation

What is it?

The ZIMD has been inspiring girls in “Roberta workshops” for programming and technology since 2006. The workshops were originally based on Lego Mindstorms RCX, a robot that was released in 1998. The Roberta project was developed by the Fraunhofer Institute St. Augustin and adopted by the ZIMD and refined didactically. For example, we focus on 10-year-old girls because the evaluations and experience show that girls at this age are even more flexible in their self-image and can therefore imagine being a technician more easily than later in puberty.

There have been two new Lego Mindstorms releases and RCX has not been supported for a long time. However, since the RCX-based Roberta models are considerably more connectable for the target group of the ZIMD, we have stuck to these models so far and have taken good care of our old robots and notebooks. However, it was time to adapt the technology to the times.

With the Robo4girls project, we have technically raised our “Robertas” to a new level and thus also adapted the workshop concept.

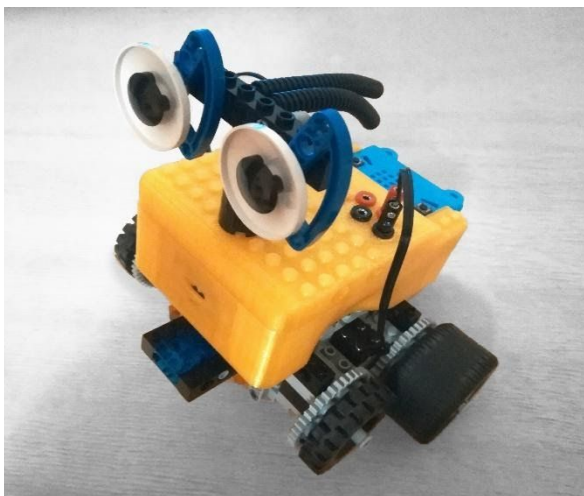
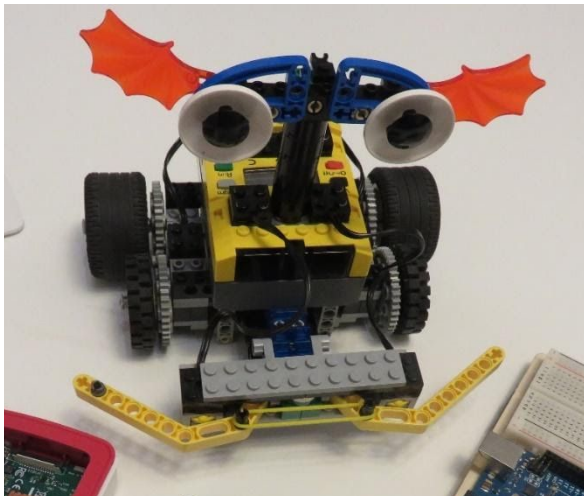

Roberta old □ *Roberta new*

The core of the old "Robertas" was the Lego Mindstorms RCX. The core of the new Robertas are the "R4Gs" we have developed. These are based on Micro: Bit and a Waveshare Motorboard, have a 3D print housing and their own, even simpler software. We (ZIMD) continue to use our Lego bodies and RCX motors as chassis, because it is important to us that the girls build something in the workshops first. However, if you do not have these Lego parts, you can fall back on a finished chassis with motors.

For whom is it?

The new R4G is for teachers, parents and children who are interested in robots. With the R4G, children can assemble a robot with the help of their parents or teachers and then use our R4G software to program them on tablets, cell phones or laptops.

The tasks to be solved have different levels of difficulty:

1. **3D printing housing, one-time:** Can be ordered, e.g. in Vienna at the 3Dee-Store (<https://3dee.at/>); or made in a maker space. Attention: In our experience, Lego knobs are quite difficult to print. Experience required.
2. **Hardware assembly (inner workings), firmware installation, testing:** adults or skillful young people. At least support from this is required.
3. **Assembly of body with R4G and head ("Roberta"):** Children from 9-10 years, with support from 8. We have the Robertas disassembled again and again in the workshops, because it is always a sense of achievement for the children, even one To build robots.
4. **Programming:** children from 8 years.

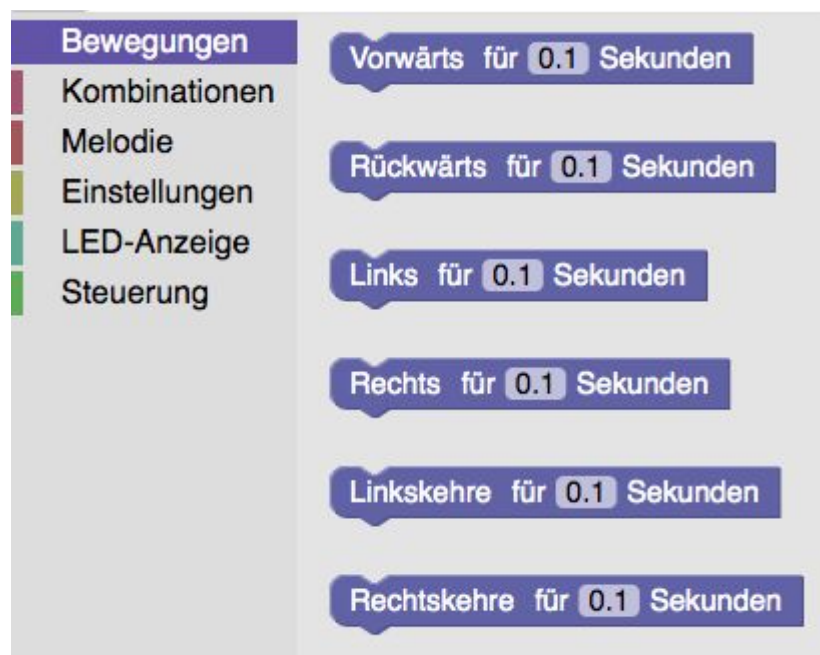

The software is extremely easy to use, there are only a few commands (motor commands such as "forward", "right turn", "zigzag"; some melodies, some LED display commands such as "heart" and a loop). We designed the software based on 14 years of experience in workshops with this target group. It is an excellent introduction to programming.

However, the software, like MakeCode, Scratch or NEPO, is based on Blockly; that means it has blocks that look the same as other youth-oriented programming languages.



Switching to these languages is therefore easy and getting started easier.

There are also numerous programming examples for the Micro:bit without the use of robots: <https://makecode.microbit.org/#>

How does it work?

We differentiate between two types of users: People with a basic technical understanding who want to build R4Gs according to our concept, for example to use them in the classroom or with their children. And the people who then hold workshops with our R4Gs. Additional Lego parts are required for both, as they were included in Lego Mindstorms RCX kits.

In principle, our software and our concept can also be used in a modified form without Lego. This is outside of the Robo4girls project and has not yet been worked out by us.

This document provides an overview of the instructions and files we provide. It has the following sections:

5. **Produce R4G**
6. **Roberta workshops with R4G**

Detailed instructions for all elements can be found under "Results" at the bottom of the page <https://www.netidee.at/robo4girls>. In detail these are the following files:

Produce R4G

1. **Hardware manufacturing instructions (interior).** The manufacturing instructions contain
 - o Instructions and tips for 3D printing
 - o tool requirements
 - o Assembly instructions
 - o and for wiringYou find it under "[Fertigungsanleitung](#)" on the [netidee project site](#).
2. **Parts** list for the order:
https://www.netidee.at/sites/default/files/2020-09/R4G_Bestellliste_V10_.pdf.
3. **3D printing housing:** 3D model can be downloaded from [here \(direct download for V10\)](#) or the "[Bauanleitung/3D Modell](#)" directory on the github project site.
4. **Hex files:** The Micro: bit must be connected to a computer via USB and one of the r4g-microbit.hex files must be transferred to the Micro: bit. The instructions for this can be found in the ReadME on <https://github.com/ZimdVienna/Robo4girls>.
You find the .hex files in the microbit folder on our github page here: <https://github.com/ZimdVienna/Robo4girls/tree/master/microbit>. To download a file, click on the file and copy its URL once it's opened. Copy the URL to the file to [DownGit](#) and click on Download. With the R4G, the file ws-r4g hex file is to be used and it can be downloaded via this link directly: [ws-r4g-microbit hex file](#).
5. **Test instructions** are located at [R4G Prüfanleitung](#) and contains instructions for
 - testing housings
 - testing of all functions.

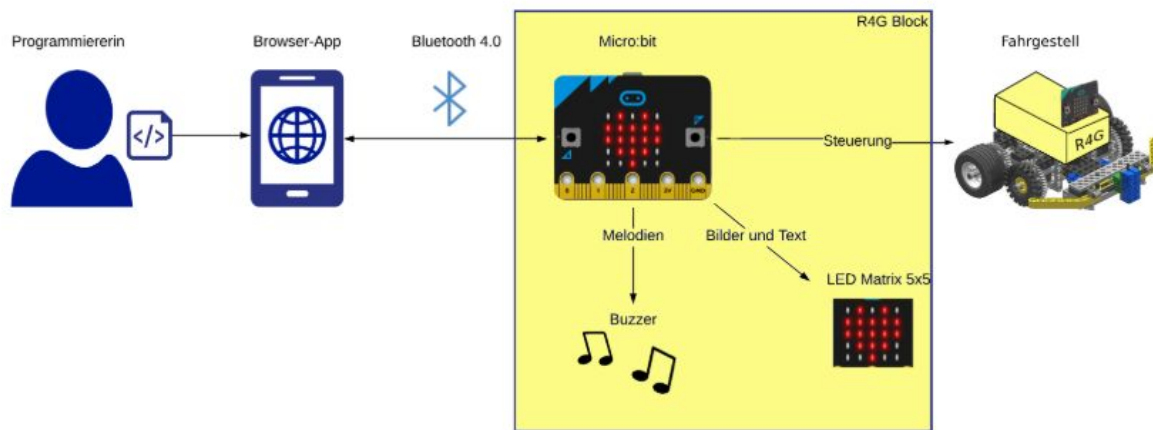

Roberta-Courses with R4G

1. **Workshop guide Roberta with R4G:** This guide leads you through a Roberta workshop based on the R4G. The building instructions, optionally the instructions for the heads, tablets and the software are also required for the workshop. All preparatory measures are described in the guidelines. The guide can be downloaded from [Workshop Leitfaden](#) (in German).
2. **Building instructions Roberta with R4G:** The building instructions for the Roberta can be found at [Bauanleitungen für Schnupper-Workshops](#). There are optional building instructions for the heads, which we only use if the children cannot think of what they could do. These are located here: [R4G head ideas](#).
3. **R4G app:** To program the R4Gs, you need tablets (recommended) or mobile devices with bluetooth and WiFi connection and the R4G software. WLAN is required for programming. WLAN and Bluetooth must be activated on the tablets. The tablets connect to the app via WLAN and to the Micro: bits via Bluetooth. Since WLAN is often not available in schools, we always have a "cube" with a fast SIM card. It makes sense for the teacher to work with a tablet with a micro HDMI output, as well as a projector and an HDMI to micro HDMI cable, so that the functionality of the software can be demonstrated. (But not all tablets need such an exit.) The way the software works is very simple and a very good start, as we have heard several times during the project. It is explained in the guide above. The R4G app can be found at <https://zimdvienna.github.io/Robo4girls/> (in German).

We would like to thank the **Internet Privatstiftung Austria**, which promoted this project as part of the **Netidee**, and the **Kapsch TrafficCom**, which supported us with the development of the housing.